

Application Note

Calibration Procedure for Video Equipment

Products:

CCVS + COMPONENT GENERATOR	SAF
CCVS GENERATOR	SFF
TV GENERATORS	SG.F
VIDEO ANALYZER	UAF
VIDEO MEASUREMENT SYSTEM	VSA

Calibration Procedure for Video Equipment

Since the video signal - composite or component - is a most complex one regarding the spectral density or even the group delay in the baseband, you need special procedures to measure the signal parameters with an objective and absolute accuracy of less than one percent over the whole frequency range up to 6 MHz.

The following describes a method allowing the precise measurement of a baseband signal, which then may be taken for the calibration of video analyzers such as the well-known R&S units UAF or UVF and future products.

How to measure the level of low frequency signal elements like the white bar

This is done by DC-coupled sampling techniques with a sampling time of about 1 μ s or less. A sync separator together with a shiftable sampling pulse allows the measurement of the level of the white bar in a line frequent video signal by taking a sample in the middle of the bar and another sample on the black level using a DC-voltmeter with high input impedance ($> 100 \text{ M}\Omega$) like the R&S Digital Multimeter UDS 5. The difference between the two levels yields the white level. The method uses analog circuitry or also a high precision (and high speed) 12 bit A/D converter.

Of course this measurement procedure must first be calibrated and verified. This is done by sampling DC voltages with the same source resistance (normally 75Ω from DC to 10 MHz) as the generator's output. Remember that DC may be measured with an absolute accuracy of better than 0.01% using normal resolution voltmeters. By comparing the results of the sampling method and the voltmeter reading the accuracy is verified.

Whith this method - described in the "Pflichtenheft Nr 8/1.1" page 9 and 10 (see annex 2) - you attain an accuracy of 0.1% (or even better) for the value of the white bar amplitude.

This method allow the parameters:

- bar amplitude
- sync amplitude
- line time non-linearity

grey level, etc. to be measured according to the CCIR recommendations (CCIR Rec. 473, 567, 569) because you may select the measuring points by shifting the sampling pulse.

How to measure the level of signal elements in the frequency range 0.1 to 6 MHz such as the sinewave packets of a multiburst

As you know it is a special problem to measure the amplitude vs frequency response of generator signals with high precision. The prerequisite is that the measurement should have an absolute accuracy of better than 0.5%. The solution is to use a thermal probe which measures the power of the input signal.

The thermal probes are available for the frequency range from DC to some GHz such as the R&S Power Meter NRVS with the thermal probe NRV-Z51 (50 Ω) and the impedance converter RAM 75/50 Ω .

This probe must first be calibrated too with sinewaves from 100 kHz to 6 MHz for the above mentioned purpose. The overall harmonics of these sinewaves must not exceed 50 dB, otherwise the distortion range must be less than $\pm 0.2\%$. Such sinewave generators are available. A frequently used one is the Synthesizer/Level Generator HP 3336C with option 005. In comparison with the DC measurement, with the thermal probe you get absolute values for the measuring head in use.



Bild 1 Calibrating the thermal probe and the power meter from DC to 6 MHz

Having done this calibration you switch over the video generator to a continuous sinewave generator gain in the range of 0.1 to 6 MHz. The new video generators of R&S are provided with this feature either by changing the firmware in case of SGPF and SGMF or by selecting the (hidden) adjust menu in case of SAF and SFF.

The next step is to measure the sinewave signals produced by the video generators with the same method the calibration of the thermal probe was done. The result you obtain is the amplitude vs frequency response of the video generator's output. This response corresponds exactly to the video signal's frequency response.

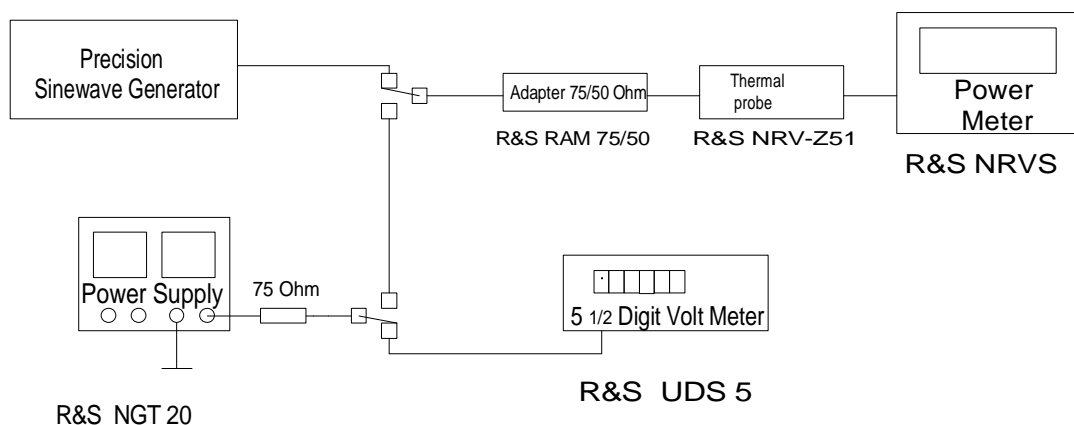

Bild 2 Calibrating the Amplitude vs Frequency Response of the Video Generators SGPF, SGMF, SAF and SFF

You thus know the exact values for

- bar amplitude
- frequency response from 100 kHz up to 6 MHz

in the signal generated by the video generators SGPF, SGMF, SAF and SFF.

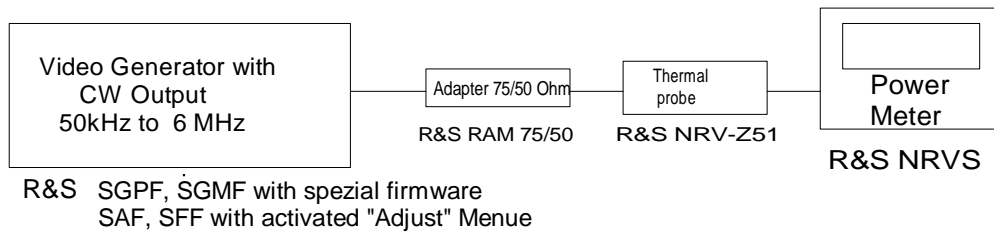
The accuracy is

for bar amplitude < 0.1 % and
for the range 100 kHz up to 6 MHz < 0.5%.

What about the 2T pulse?

The 2T pulse is generated as a \cos^2 pulse and has therefore a broad spectrum with significant spectral power up to approximately 8 MHz. The main part of spectral power is at low frequencies. The question is now what influence has an uneven frequency response on the 2T pulse amplitude,

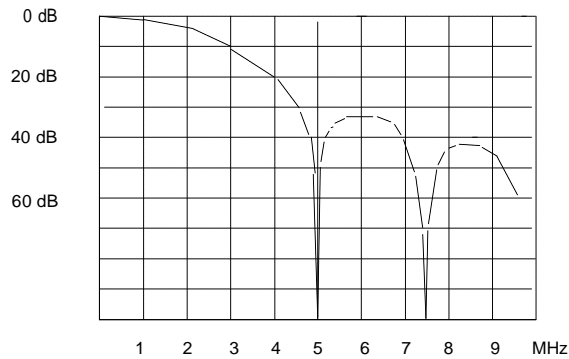

Fig. 3 Spectral density of the 2T Pulse

As we have seen above, the adjustment of the frequency response of the antialiasing output filters like they are used in all-digital video generators has to be very accurate at lower frequencies. Some difficulties may appear at frequencies from 2 MHz to 6 MHz, especially in the region of the subcarrier.

The great advantage here lies in the fact that the main spectral power of the 2T pulse is in the low frequency range which can easily be held flat. On the other hand we have to determine the influence of distorted flatness in the upper frequency range. To achieve this, extensive calculations have been done. The investigations showed deviations of $\pm 5\%$ from the flat response at 6 MHz with RC characteristics and at the subcarrier as a deviation of $\pm 5\%$ with bandpass characteristics and a bandwidth of about 2 MHz.

The calculation of the 2T pulse amplitude at these distortions showed amplitude differences of less than 0.8% in the worst case. Provided that the test field engineer can attain an accuracy of better than 1% in the adjustment of the output filter (an accuracy easily to obtain) the error of the 2T pulse amplitude is reduced to about 0.2%. This is an acceptable calibration value for the complex 2T pulse.

How to calibrate differential gain and phase

Differential gain and phase are distortions of the subcarrier caused by nonlinearities dependent on the luminance level. If you measure a subcarrier superimposed on a constant luminance, these distortions should be zero. Now it is easy to find a calibration signal for these parameters to be adjusted to zero:

You create with the video generators SAF or SFF from R&S a new VIT signal similar to the signal CCIR 330/5 but without the luminance staircase where the subcarrier is superimposed. Within this signal differential gain and phase should be zero because on the subcarrier part the luminance does not change.

To be sure that there is no influence from the digital signal generation you might superimpose an analog subcarrier to the modified test signal not by SIGNAL EDIT but via the EXT 2 input of the video generators SAF or SFF onto the active part of the video line with $V_{SS} = 280 \pm 10 \text{ mV}$ and $f = 4\,433\,618.75 \pm 10 \text{ Hz}$. Using this special signal you are able to adjust in your video analyzer the parameters differential gain and differential phase exactly to zero.

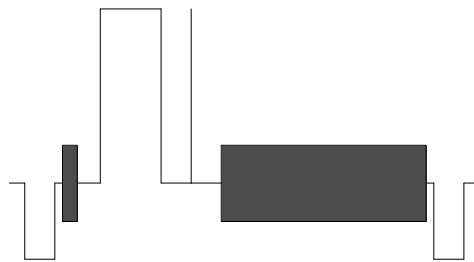

Fig 4 Modified Signal CCIR 330

How to calibrate group delay

As there is really no way to measure the absolute value of group delay with test signals, you must try to find a way to define this parameter using some reference measurement. Absolute measurement is not possible because equipment used such as oscilloscopes, video analyzers and similar units have errors in the range of the accuracy of the value needed for calibrating the parameter group delay. With the new TV Network Analyzer SWVF or SWKF from R&S it should be no problem to adjust such a filter not only in amplitude against frequency with the demanded accuracy of 1% but also to ensure that the group delay is within a ripple of 5ns. This ripple is then compared with a reference measurement using SWVF or SWKF with a short coax cable as device under test.

Since this cable produces no group delay in the frequency range of interest, the difference of the two measurements represents the group delay of the signal path behind the D/A converter to the output connector of the digital video generator with a resolution of 1ns or better.

Video generators such as R&S SGPF, SGMF, SAF and SFF calculate by definition the output signals with negligible distortions. The following 12 bit D/A converter generates the signals therefore with a flat group delay. The group delay within the signals at the output of the generators is then only determined by the output filters of the R&S video generators. This group delay was measured with an accuracy of about 1 ns using the procedure described above. This is why the group delay for example of the 20 T pulse also is known exactly for calibration purpose.

These generators can now be used as standard units to calibrate all types of video analyzers such as the well-known R&S UVF or UAF, the same way it is done in the R&S test and service departments. Normally it is sufficient to calibrate either a generator or an analyzer by this procedure which should then be repeated at intervals of one year. These instruments then are the standard units to calibrate all other equipment.

In order to guarantee highest precision, video generators should be calibrated in a climatic chamber at 23 ± 3 °C. Of course all values are measured automatically controlled by IEEE 488 (IEC 625) bus. This also makes it possible to average the results several times to reach stable conditions.

It is recommended to verify all signals by checking on an oscilloscope.

This is precisely done by the procedure described above, for ensuring that the right signals are used at the right time.

How to verify the linearity of a video analyzer

The aim of all the previous measurements was to calibrate the video analyzer at the zero points of the parameter values. What now remains is the check of the linearity of the displayed parameter values over the entire measurement range.

With the brand new video generators SAF and SFF you have the possibility to test this without additional equipment such as the DISTORTION NETWORK UPF-Z. This network produces defined linear and non linear distortions at signal which pass through. The analyzer receiving these signals should show the predefined video parameter values.

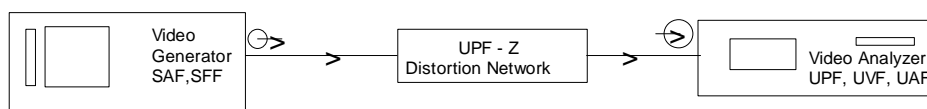

Fig 5 Checking Video Analyzers by means of the Distortion Network UPF-Z

The SIGNAL EDIT feature of SAF and SFF allows you to create special test signals with predistorted signal elements. In the annex 1 you find lists of signal descriptions for these calibration signals and the necessary VITS groups which easily show the user how to generate them. The parameter values show distortions of $\pm 5\%$ and $\pm 10\%$. If more deviation is wanted, the customer will be able to create his own distorted signals in a few minutes and test his instrument



Fig 6 Checking Video Analyzers with predistorted testsignals

Because of the high resolution of 12 bits in signal generation you can be sure that the R&S video generators SAF and SFF output edited signals with extremely high precision in the amplitude range from -6 dB to + 3 dB. So you are able to calibrate video analyzers like the UAF or UVF from R&S over the full measurement range.

Annex 1

1.Explanation of Signal File Names

1st letterblock:	0	⇒	0% distortion (normal signal)
	N05	⇒	all signal elements are distorted by -5 % (-5ns)
	N10	⇒	all signal elements are distorted by -10 % (-10ns)
	P05	⇒	all signal elements are distorted by +5 % (+5ns)
	P10	⇒	all signal elements are distorted by +10 % (+10ns)
2nd letterblock:	CAL	⇒	indicator for calibration signal
3rd letterblock:	17	⇒	CCIR 17
	18	⇒	CCIR 18
	30	⇒	CCIR 330
	31	⇒	CCIR 331
	RT	⇒	Residual Picture Carrier

2.Lists of signaldecriptions for calibration applications

2.1 Distortions 0 % (calibrated signal)

Data set for signal OCAL17

SIN ² -TRANSITION	12.000 µs	200 ns	300 ns	700.0 mV	0.0 mV	0.0°
SIN ² -TRANSITION	22.000 µs	200 ns	300 ns	0.0 mV	0.0 mV	0.0°
2T PULSE	26.000 µs	700 mV				
SIN ² -TRANSITION	30.975 µs	1000 ns	300 ns	350.0 mV	0.0 mV	0.0°
SIN ² -TRANSITION	33.025 µs	1000 ns	300 ns	- 1.0 mV	0.0 mV	0.0°
SIN ² -TRANSITION	40.000 µs	200 ns	300 ns	140.0 mV	0.0 mV	0.0°
SIN ² -TRANSITION	44.000 µs	200 ns	300 ns	280.0 mV	0.0 mV	0.0°
SIN ² -TRANSITION	48.000 µs	200 ns	300 ns	420.0 mV	0.0 mV	0.0°
SIN ² -TRANSITION	52.000 µs	200 ns	300 ns	560.0 mV	0.0 mV	0.0°
SIN ² -TRANSITION	56.000 µs	200 ns	300 ns	700.0 mV	0.0 mV	0.0°
SIN ² -TRANSITION	62.000 µs	200 ns	300 ns	0.0 mV	0.0 mV	0.0°
OVERLAY FREQ.	29.925 µs	4.000 µs	1000 ns	4433 kHz	21°	700.0 mV
BURST						

Data set for signal OCAL18

SIN ² -TRANSITION	12.000 µs	200 ns	300 ns	560.0 mV	0.0 mV	0.0°
SIN ² -TRANSITION	16.000 µs	200 ns	300 ns	140.0 mV	0.0 mV	0.0°
SIN ² -TRANSITION	20.000 µs	200 ns	300 ns	350.0 mV	0.0 mV	0.0°
FREQ. BURST	24.000 µs	4.000 µs	100 ns	500 kHz	0°	420.0 mV
FREQ. BURST	30.000 µs	5.000 µs	100 ns	1000 kHz	0°	420.0 mV
FREQ. BURST	36.000 µs	5.500 µs	100 ns	2000 kHz	0°	420.0 mV
FREQ. BURST	42.000 µs	5.500 µs	200 ns	4000 kHz	0°	420.0 mV
FREQ. BURST	48.000 µs	5.500 µs	500 ns	4800 kHz	0°	420.0 mV
FREQ. BURST	53.500 µs	6.000 µs	1000 ns	5800 kHz	0°	420.0 mV
SIN ² -TRANSITION	62.000 µs	200 ns	300 ns	0.0 mV	0.0 mV	0.0°

Data set for signal OCAL30

SIN ² -TRANSITION	12.000 µs	200 ns	300 ns	700.0 mV	0.0 mV	0.0°
SIN ² -TRANSITION	22.000 µs	200 ns	300 ns	0.0 mV	0.0 mV	0.0°
2T PULSE	26.000 µs	700.0 mV				
SIN ² -TRANSITION	30.000 µs	200 ns	1000 ns	0.0 mV	80.1 mV	98.6 mV
SIN ² -TRANSITION	40.000 µs	231 ns	1000 ns	140.0 mV	80.1 mV	98.6 mV
SIN ² -TRANSITION	44.000 µs	231 ns	1000 ns	280.0 mV	80.1 mV	98.6 mV
SIN ² -TRANSITION	48.000 µs	231 ns	1000 ns	420.0 mV	80.1 mV	98.6 mV
SIN ² -TRANSITION	52.000 µs	231 ns	1000 ns	560.0 mV	80.1 mV	98.6 mV
SIN ² -TRANSITION	56.000 µs	231 ns	1000 ns	700.0 mV	80.1 mV	98.6 mV
SIN ² -TRANSITION	60.000 µs	200 ns	1000 ns	700.0 mV	0.0 mV	0.0 mV
SIN ² -TRANSITION	62.000 µs	200 ns	300 ns	0.0 mV	0.0 mV	0.0 mV

Data set for signal OCAL31

SIN ² -TRANSITION	12.000 µs	200 ns	300 ns	350.0 mV	0.0 mV	0.0°
SIN ² -TRANSITION	14.000 µs	200 ns	1000 ns	350.0 mV	140.0 mV	60.0°
SIN ² -TRANSITION	18.000 µs	200 ns	1000 ns	350.0 mV	420.0 mV	60.0°
SIN ² -TRANSITION	22.000 µs	200 ns	1000 ns	350.0 mV	700.0 mV	60.0°
SIN ² -TRANSITION	28.000 µs	200 ns	1000 ns	350.0 mV	0.0 mV	0.0°
SIN ² -TRANSITION	34.000 µs	200 ns	1000 ns	350.0 mV	420.0 mV	60.0°
SIN ² -TRANSITION	60.000 µs	200 ns	1000 ns	350.0 mV	0.0 mV	0.0°
SIN ² -TRANSITION	62.000 µs	200 ns	300 ns	0.0 mV	0.0 mV	0.0°

Data set for signal OCALRT (the RES P C parameter value is 10 %
BAR AMPL and SYNC = 0 %)

SIN ² -TRANSITION	12.000 µs	200 ns	300 ns	800.0 mV	0.0 mV	0.0°
SIN ² -TRANSITION	62.000 µs	200 ns	300 ns	0.0 mV	0.0 mV	0.0°

2.2 Distortions - 5 % (- 5 ns)

Data set for signal N05CAL17

SIN ² -TRANSITION	12.000 µs	200 ns	300 ns	681.6 mV	0.0 mV	0.0°
SIN ² -TRANSITION	13.500 µs	200 ns	1000 ns	665.0 mV	0.0 mV	0.0°
SIN ² -TRANSITION	20.500 µs	200 ns	1000 ns	648.4 mV	0.0 mV	0.0°
SIN ² -TRANSITION	22.000 µs	200 ns	1000 ns	-33.3 mV	0.0 mV	0.0°
SIN ² -TRANSITION	23.500 µs	200 ns	1000 ns	0.0 mV	0.0 mV	0.0°
2T PULSE	25.200 µs	-33.3 mV				
2T PULSE	26.000 µs	631.8 mV				
2T PULSE	26.800 µs	33.3 mV				
SIN ² -TRANSITION	30.975 µs	1000 ns	1000 ns	315.9 mV	0.0 mV	0.0°
SIN ² -TRANSITION	33.025 µs	1000 ns	1000 ns	0.0 mV	0.0 mV	0.0°
SIN ² -TRANSITION	40.000 µs	200 ns	300 ns	129.7 mV	0.0 mV	0.0°
SIN ² -TRANSITION	44.000 µs	200 ns	300 ns	261.0 mV	0.0 mV	0.0°
SIN ² -TRANSITION	48.000 µs	200 ns	300 ns	394.0 mV	0.0 mV	0.0°
SIN ² -TRANSITION	52.000 µs	200 ns	300 ns	528.7 mV	0.0 mV	0.0°
SIN ² -TRANSITION	56.000 µs	200 ns	300 ns	665.0 mV	0.0 mV	0.0°
SIN ² -TRANSITION	62.000 µs	200 ns	300 ns	0.0 mV	0.0 mV	0.0°
OVERLAY FREQ. BURST	29.875 µs	4.000 µs	1000 ns	4433 kHz	21°	631.8 mV

Data set for signal N05CAL18

SIN ² -TRANSITION	12.000 µs	200 ns	300 ns	560.0 mV	0.0 mV	0.0°
SIN ² -TRANSITION	16.000 µs	200 ns	300 ns	140.0 mV	0.0 mV	0.0°
SIN ² -TRANSITION	20.000 µs	200 ns	300 ns	350.0 mV	0.0 mV	0.0°
FREQ. BURST	24.000 µs	4.000 µs	100 ns	500 kHz	0°	416.5 mV
FREQ. BURST	30.000 µs	5.000 µs	100 ns	1000 kHz	0°	413.0 mV
FREQ. BURST	36.000 µs	5.500 µs	100 ns	2000 kHz	0°	409.5 mV
FREQ. BURST	42.000 µs	5.500 µs	200 ns	4000 kHz	0°	406.0 mV
FREQ. BURST	48.000 µs	5.500 µs	500 ns	4800 kHz	0°	402.5 mV
FREQ. BURST	53.500 µs	6.000 µs	1000 ns	5800 kHz	0°	399.0 mV
SIN ² -TRANSITION	62.000 µs	200 ns	300 ns	0.0 mV	0.0 mV	0.0°

Data set for signal N05CAL30

SIN ² -TRANSITION	12.000 µs	200 ns	300 ns	681.6 mV	0.0 mV	0.0°
SIN ² -TRANSITION	13.500 µs	200 ns	1000 ns	665.0 mV	0.0 mV	0.0°
SIN ² -TRANSITION	20.500 µs	200 ns	1000 ns	648.4 mV	0.0 mV	0.0°
SIN ² -TRANSITION	22.000 µs	200 ns	1000 ns	-33.3 mV	0.0 mV	0.0°
SIN ² -TRANSITION	23.500 µs	200 ns	1000 ns	0.0 mV	0.0 mV	0.0°
2T PULSE	25.200 µs	-33.3 mV				
2T PULSE	26.000 µs	631.8 mV				
2T PULSE	26.800 µs	33.3 mV				
SIN ² -TRANSITION	30.000 µs	200 ns	1000 ns	0.0 mV	280.0 mV	63.0°
SIN ² -TRANSITION	40.000 µs	231 ns	1000 ns	140.0 mV	277.2 mV	62.0°
SIN ² -TRANSITION	44.000 µs	231 ns	1000 ns	280.0 mV	274.5 mV	61.0°
SIN ² -TRANSITION	48.000 µs	231 ns	1000 ns	420.0 mV	271.6 mV	60.0°
SIN ² -TRANSITION	52.000 µs	231 ns	1000 ns	560.0 mV	268.9 mV	59.0°
SIN ² -TRANSITION	56.000 µs	231 ns	1000 ns	700.0 mV	266.0 mV	58.0°
SIN ² -TRANSITION	60.000 µs	200 ns	1000 ns	700.0 mV	0.0 mV	0.0°
SIN ² -TRANSITION	62.000 µs	200 ns	300 ns	0.0 mV	0.0 mV	0.0°

Data set for signal N05CAL31

SIN ² -TRANSITION	12.000 µs	200 ns	300 ns	350.0 mV	0.0 mV	0.0°
SIN ² -TRANSITION	14.000 µs	1000 ns	1000 ns	338.3 mV	126.5 mV	62.5°
SIN ² -TRANSITION	18.000 µs	1000 ns	1000 ns	326.7 mV	388.9 mV	60.0°
SIN ² -TRANSITION	22.000 µs	1000 ns	1000 ns	315.0 mV	665.1 mV	57.5°
SIN ² -TRANSITION	28.000 µs	1000 ns	1000 ns	350.0 mV	0.0 mV	0.0°
SIN ² -TRANSITION	34.000 µs	1000 ns	1000 ns	326.7 mV	388.9 mV	60.0°
SIN ² -TRANSITION	60.000 µs	1000 ns	1000 ns	350.0 mV	0.0 mV	0.0°
SIN ² -TRANSITION	62.000 µs	200 ns	300 ns	0.0 mV	0.0 mV	0.0°

Data set for signal N05CALRT (the RES P C parameter value is 5 %
BAR AMPL and SYNC = 0 %)

SIN ² -TRANSITION	12.000 µs	200 ns	300 ns	770.6 mV	0.0 mV	0.0°
SIN ² -TRANSITION	62.000 µs	200 ns	300 ns	0.0 mV	0.0 mV	0.0°

2.3 Distortions - 10 % (- 10 ns)

Data set for signal N10CAL17

SIN ² -TRANSITION	12.000 µs	200 ns	300 ns	661.5 mV	0.0 mV	0.0°
SIN ² -TRANSITION	13.500 µs	200 ns	1000 ns	630.0 mV	0.0 mV	0.0°
SIN ² -TRANSITION	20.500 µs	200 ns	1000 ns	598.5 mV	0.0 mV	0.0°
SIN ² -TRANSITION	22.000 µs	200 ns	1000 ns	-63.0 mV	0.0 mV	0.0°
SIN ² -TRANSITION	23.500 µs	200 ns	1000 ns	0.0 mV	0.0 mV	0.0°
2T PULSE	25.200 µs	-56.7 mV				
2T PULSE	26.000 µs	567.0 mV				
2T PULSE	26.800 µs	56.7 mV				
SIN ² -TRANSITION	30.975 µs	1000 ns	1000 ns	283.5 mV	0.0 mV	0.0°
SIN ² -TRANSITION	33.025 µs	1000 ns	1000 ns	0.0 mV	0.0 mV	0.0°
SIN ² -TRANSITION	40.000 µs	200 ns	300 ns	119.3 mV	0.0 mV	0.0°
SIN ² -TRANSITION	44.000 µs	200 ns	300 ns	241.9 mV	0.0 mV	0.0°
SIN ² -TRANSITION	48.000 µs	200 ns	300 ns	368.0 mV	0.0 mV	0.0°
SIN ² -TRANSITION	52.000 µs	200 ns	300 ns	497.4 mV	0.0 mV	0.0°
SIN ² -TRANSITION	56.000 µs	200 ns	300 ns	630.0 mV	0.0 mV	0.0°
SIN ² -TRANSITION	62.000 µs	200 ns	300 ns	0.0 mV	0.0 mV	0.0°
OVERLAY FREQ.	29.825 µs	4.000 µs	1000 ns	4433 kHz	21°	567.0 mV
BURST						

Data set for signal N10CAL18

SIN ² -TRANSITION	12.000 µs	200 ns	300 ns	560.0 mV	0.0 mV	0.0°
SIN ² -TRANSITION	16.000 µs	200 ns	300 ns	140.0 mV	0.0 mV	0.0°
SIN ² -TRANSITION	20.000 µs	200 ns	300 ns	350.0 mV	0.0 mV	0.0°
FREQ. BURST	24.000 µs	4.000 µs	100 ns	500 kHz	0°	413.0 mV
FREQ. BURST	30.000 µs	5.000 µs	100 ns	1000 kHz	0°	406.0 mV
FREQ. BURST	36.000 µs	5.500 µs	100 ns	2000 kHz	0°	399.0 mV
FREQ. BURST	42.000 µs	5.500 µs	200 ns	4000 kHz	0°	392.0 mV
FREQ. BURST	48.000 µs	5.500 µs	500 ns	4800 kHz	0°	385.0 mV
FREQ. BURST	53.500 µs	6.000 µs	1000 ns	5800 kHz	0°	378.0 mV
SIN ² -TRANSITION	62.000 µs	200 ns	300 ns	0.0 mV	0.0 mV	0.0°

Data set for signal N10CAL30

SIN ² -TRANSITION	12.000 µs	200 ns	300 ns	661.5 mV	0.0 mV	0.0°
SIN ² -TRANSITION	13.500 µs	200 ns	1000 ns	630.0 mV	0.0 mV	0.0°
SIN ² -TRANSITION	20.500 µs	200 ns	1000 ns	598.5 mV	0.0 mV	0.0°
SIN ² -TRANSITION	22.000 µs	200 ns	1000 ns	-63.0 mV	0.0 mV	0.0°
SIN ² -TRANSITION	23.000 µs	200 ns	1000 ns	0.0 mV	0.0 mV	0.0°
2T PULSE	25.200 µs	-56.7 mV				
2T PULSE	26.000 µs	567.0 mV				
2T PULSE	26.800 µs	56.7 mV				
SIN ² -TRANSITION	30.000 µs	200 ns	1000 ns	0.0 mV	280.0 mV	66.0°
SIN ² -TRANSITION	40.000 µs	231 ns	1000 ns	140.0 mV	274.3 mV	64.0°
SIN ² -TRANSITION	44.000 µs	231 ns	1000 ns	280.0 mV	268.9 mV	62.0°
SIN ² -TRANSITION	48.000 µs	231 ns	1000 ns	420.0 mV	263.1 mV	60.0°
SIN ² -TRANSITION	52.000 µs	231 ns	1000 ns	560.0 mV	257.7 mV	58.1°
SIN ² -TRANSITION	56.000 µs	231 ns	1000 ns	700.0 mV	252.0 mV	56.0°
SIN ² -TRANSITION	60.000 µs	200 ns	1000 ns	700.0 mV	0.0 mV	0.0°
SIN ² -TRANSITION	62.000 µs	200 ns	300 ns	0.0 mV	0.0 mV	0.0°

Data set for signal N10CAL31

SIN ² -TRANSITION	12.000 µs	200 ns	300 ns	350.0 mV	0.0 mV	0.0°
SIN ² -TRANSITION	14.000 µs	1000 ns	1000 ns	326.7 mV	113.4 mV	65.0°
SIN ² -TRANSITION	18.000 µs	1000 ns	1000 ns	303.3 mV	359.1 mV	60.0°
SIN ² -TRANSITION	22.000 µs	1000 ns	1000 ns	280.0 mV	630.0 mV	55.0°
SIN ² -TRANSITION	28.000 µs	1000 ns	1000 ns	350.0 mV	0.0 mV	0.0°
SIN ² -TRANSITION	34.000 µs	1000 ns	1000 ns	303.3 mV	359.1 mV	60.0°
SIN ² -TRANSITION	60.000 µs	1000 ns	1000 ns	350.0 mV	0.0 mV	0.0°
SIN ² -TRANSITION	62.000 µs	200 ns	300 ns	0.0 mV	0.0 mV	0.0°

Data set for signal N10CALRT (the RES P C parameter value is 0 %
BAR AMPL and SYNC = 0 %)

SIN ² -TRANSITION	12.000 µs	200 ns	300 ns	700.0 mV	0.0 mV	0.0°
SIN ² -TRANSITION	62.000 µs	200 ns	300 ns	0.0 mV	0.0 mV	0.0°

2.4 Distortions +-5 % (-+5 ns)

Data set for signal P05CAL17

SIN ² -TRANSITION	12.000 µs	200 ns	300 ns	716.6 mV	0.0 mV	0.0°
SIN ² -TRANSITION	13.500 µs	200 ns	300 ns	735.0 mV	0.0 mV	0.0°
SIN ² -TRANSITION	20.500 µs	200 ns	300 ns	753.4 mV	0.0 mV	0.0°
SIN ² -TRANSITION	22.000 µs	200 ns	300 ns	38.5 mV	0.0 mV	0.0°
SIN ² -TRANSITION	23.500 µs	200 ns	300 ns	0.0 mV	0.0 mV	0.0°
2T PULSE	25.200 µs	38.5 mV				
2T PULSE	26.000 µs	771.8 mV				
2T PULSE	26.800 µs	-38.5 mV				
SIN ² -TRANSITION	30.975 µs	1000 ns	300 ns	385.9 mV	0.0 mV	0.0°
SIN ² -TRANSITION	33.025 µs	1000 ns	300 ns	0.0 mV	0.0 mV	0.0°
SIN ² -TRANSITION	40.000 µs	200 ns	300 ns	150.7 mV	0.0 mV	0.0°
SIN ² -TRANSITION	44.000 µs	200 ns	300 ns	299.5 mV	0.0 mV	0.0°
SIN ² -TRANSITION	48.000 µs	200 ns	300 ns	446.6 mV	0.0 mV	0.0°
SIN ² -TRANSITION	52.000 µs	200 ns	300 ns	591.8 mV	0.0 mV	0.0°
SIN ² -TRANSITION	56.000 µs	200 ns	300 ns	735.0 mV	0.0 mV	0.0°
SIN ² -TRANSITION	62.000 µs	200 ns	300 ns	0.0 mV	0.0 mV	0.0°
OVERLAY FREQ. BURST	29.975 µs	4.000 µs	1000 ns	4433 kHz	21°	771.8 mV

Data set signal for P05CAL18

SIN ² -TRANSITION	12.000 µs	200 ns	300 ns	560.0 mV	0.0 mV	0.0°
SIN ² -TRANSITION	16.000 µs	200 ns	300 ns	140.0 mV	0.0 mV	0.0°
SIN ² -TRANSITION	20.000 µs	200 ns	300 ns	350.0 mV	0.0 mV	0.0°
FREQ. BURST	24.000 µs	4.000 µs	100 ns	500 kHz	0°	420.0 mV
FREQ. BURST	30.000 µs	5.000 µs	100 ns	1000 kHz	0°	424.2 mV
FREQ. BURST	36.000 µs	5.500 µs	100 ns	2000 kHz	0°	428.4 mV
FREQ. BURST	42.000 µs	5.500 µs	200 ns	4000 kHz	0°	432.6 mV
FREQ. BURST	48.000 µs	5.500 µs	500 ns	4800 kHz	0°	436.8 mV
FREQ. BURST	53.500 µs	6.000 µs	1000 ns	5800 kHz	0°	441.0 mV
SIN ² -TRANSITION	62.000 µs	200 ns	300 ns	0.0 mV	0.0 mV	0.0°

Data set for signal P05CAL30

SIN2-TRANSITION	12.000 µs	200 ns	300 ns	716.6 mV	0.0 mV	0.0°
SIN2-TRANSITION	13.500 µs	200 ns	300 ns	735.0 mV	0.0 mV	0.0°
SIN2-TRANSITION	20.500 µs	200 ns	300 ns	753.4 mV	0.0 mV	0.0°
SIN2-TRANSITION	22.000 µs	200 ns	300 ns	38.5 mV	0.0 mV	0.0°
SIN2-TRANSITION	23.500 µs	200 ns	300 ns	0.0 mV	0.0 mV	0.0°
2T PULSE	25.200 µs	38.5 mV				
2T PULSE	26.000 µs	771.8 mV				
2T PULSE	26.800 µs	-38.5 mV				
SIN2-TRANSITION	30.000 µs	200 ns	1000 ns	0.0 mV	279.9 mV	57.0°
SIN2-TRANSITION	40.000 µs	231 ns	1000 ns	140.0 mV	282.8 mV	58.0°
SIN2-TRANSITION	44.000 µs	231 ns	1000 ns	280.0 mV	285.5 mV	59.0°
SIN2-TRANSITION	48.000 µs	231 ns	1000 ns	420.0 mV	288.4 mV	60.0°
SIN2-TRANSITION	52.000 µs	231 ns	1000 ns	560.0 mV	291.1 mV	61.0°
SIN2-TRANSITION	56.000 µs	231 ns	1000 ns	700.0 mV	293.9 mV	62.0°
SIN2-TRANSITION	60.000 µs	200 ns	1000 ns	700.0 mV	0.0 mV	0.0°
SIN2-TRANSITION	62.000 µs	200 ns	300 ns	0.0 mV	0.0 mV	0.0°

Data set for signal P05CAL31

SIN2-TRANSITION	12.000 µs	200 ns	300 ns	350.0 mV	0.0 mV	0.0°
SIN2-TRANSITION	14.000 µs	1000 ns	1000 ns	373.3 mV	138.6 mV	55.1°
SIN2-TRANSITION	18.000 µs	1000 ns	1000 ns	396.7 mV	438.9 mV	60.0°
SIN2-TRANSITION	22.000 µs	1000 ns	1000 ns	420.0 mV	770.0 mV	65.0°
SIN2-TRANSITION	28.000 µs	1000 ns	1000 ns	350.0 mV	0.0 mV	0.0°
SIN2-TRANSITION	34.000 µs	1000 ns	1000 ns	396.7 mV	438.9 mV	60.0°
SIN2-TRANSITION	60.000 µs	1000 ns	1000 ns	350.0 mV	0.0 mV	0.0°
SIN2-TRANSITION	62.000 µs	200 ns	300 ns	0.0 mV	0.0 mV	0.0°

Data set for signal P05CALRT (the RES P C parameter value is 15 %
BAR AMPL and SYNC = 0 %

SIN2-TRANSITION	12.000 µs	200 ns	300 ns	876.5 mV	0.0 mV	0.0°
SIN2-TRANSITION	62.000 µs	200 ns	300 ns	0.0 mV	0.0 mV	0.0°

2.5 Distortions + 10 % (+ 10 ns)

Data set for signal P10CAL17

SIN2-TRANSITION	12.000 µs	200 ns	300 ns	731.5 mV	0.0 mV	0.0°
SIN2-TRANSITION	13.500 µs	200 ns	300 ns	770.0 mV	0.0 mV	0.0°
SIN2-TRANSITION	20.500 µs	200 ns	300 ns	808.5 mV	0.0 mV	0.0°
SIN2-TRANSITION	22.000 µs	200 ns	300 ns	77.0 mV	0.0 mV	0.0°
SIN2-TRANSITION	23.500 µs	200 ns	300 ns	0.0 mV	0.0 mV	0.0°
2T PULSE	25.200 µs	84.7 mV				
2T PULSE	26.000 µs	847.0 mV				
2T PULSE	26.800 µs	-84.7 mV				
SIN2-TRANSITION	30.975 µs	1000 ns	300 ns	423.5 mV	0.0 mV	0.0°
SIN2-TRANSITION	33.025 µs	1000 ns	300 ns	0.0 mV	0.0 mV	0.0°
SIN2-TRANSITION	40.000 µs	200 ns	1000 ns	162.1 mV	0.0 mV	0.0°
SIN2-TRANSITION	44.000 µs	200 ns	1000 ns	320.1 mV	0.0 mV	0.0°
SIN2-TRANSITION	48.000 µs	200 ns	1000 ns	474.1 mV	0.0 mV	0.0°
SIN2-TRANSITION	52.000 µs	200 ns	1000 ns	624.1 mV	0.0 mV	0.0°
SIN2-TRANSITION	56.000 µs	200 ns	1000 ns	770.0 mV	0.0 mV	0.0°
SIN2-TRANSITION	62.000 µs	200 ns	300 ns	0.0 mV	0.0 mV	0.0°
OVERLAY FREQ. BURST	30.025 µs	4.000 µs	1000 ns	4433 kHz	21°	847.0 mV

Data set for signal P10CAL18

SIN2-TRANSITION	12.000 µs	200 ns	300 ns	560.0 mV	0.0 mV	0.0°
SIN2-TRANSITION	16.000 µs	200 ns	300 ns	140.0 mV	0.0 mV	0.0°
SIN2-TRANSITION	20.000 µs	200 ns	300 ns	350.0 mV	0.0 mV	0.0°
FREQ. BURST	24.000 µs	4.000 µs	100 ns	500 kHz	0°	420.0 mV
FREQ. BURST	30.000 µs	5.000 µs	100 ns	1000 kHz	0°	425.0 mV
FREQ. BURST	36.000 µs	5.500 µs	100 ns	2000 kHz	0°	436.8 mV
FREQ. BURST	42.000 µs	5.500 µs	200 ns	4000 kHz	0°	445.2 mV
FREQ. BURST	48.000 µs	5.500 µs	500 ns	4800 kHz	0°	453.6 mV
FREQ. BURST	53.500 µs	6.000 µs	1000 ns	5800 kHz	0°	462.0 mV
SIN2-TRANSITION	62.000 µs	200 ns	300 ns	0.0 mV	0.0 mV	0.0°

Data set for signal P10CAL30

SIN2-TRANSITION	12.000 µs	200 ns	300 ns	735.0 mV	0.0 mV	0.0°
SIN2-TRANSITION	13.500 µs	200 ns	300 ns	770.0 mV	0.0 mV	0.0°
SIN2-TRANSITION	20.500 µs	200 ns	300 ns	805.0 mV	0.0 mV	0.0°
SIN2-TRANSITION	22.000 µs	200 ns	300 ns	77.0 mV	0.0 mV	0.0°
SIN2-TRANSITION	23.500 µs	200 ns	300 ns	0.0 mV	0.0 mV	0.0°
2T PULSE	25.200 µs	84.7 mV				
2T PULSE	26.000 µs	847.0 mV				
2T PULSE	26.800 µs	-84.7 mV				
SIN2-TRANSITION	30.000 µs	200 ns	1000 ns	0.0 mV	280.1 mV	54.0°
SIN2-TRANSITION	40.000 µs	231 ns	1000 ns	140.0 mV	286.3 mV	56.0°
SIN2-TRANSITION	44.000 µs	231 ns	1000 ns	280.0 mV	292.4 mV	58.0°
SIN2-TRANSITION	48.000 µs	231 ns	1000 ns	420.0 mV	298.3 mV	60.0°
SIN2-TRANSITION	52.000 µs	231 ns	1000 ns	560.0 mV	304.8 mV	62.0°
SIN2-TRANSITION	56.000 µs	231 ns	1000 ns	700.0 mV	311.2 mV	64.0°
SIN2-TRANSITION	60.000 µs	200 ns	1000 ns	700.0 mV	0.0 mV	0.0°
SIN2-TRANSITION	62.000 µs	200 ns	300 ns	0.0 mV	0.0 mV	0.0°

Data set for signal P10CAL31

SIN2-TRANSITION	12.000 µs	200 ns	300 ns	350.0 mV	0.0 mV	0.0°
SIN2-TRANSITION	14.000 µs	1000 ns	1000 ns	373.3 mV	138.6 mV	55.1°
SIN2-TRANSITION	18.000 µs	1000 ns	1000 ns	396.7 mV	438.9 mV	60.0°
SIN2-TRANSITION	22.000 µs	1000 ns	1000 ns	420.0 mV	770.0 mV	65.0°
SIN2-TRANSITION	28.000 µs	1000 ns	1000 ns	350.0 mV	0.0 mV	0.0°
SIN2-TRANSITION	34.000 µs	1000 ns	1000 ns	396.7 mV	438.9 mV	60.0°
SIN2-TRANSITION	60.000 µs	1000 ns	1000 ns	350.0 mV	0.0 mV	0.0°
SIN2-TRANSITION	62.000 µs	200 ns	300 ns	0.0 mV	0.0 mV	0.0°

Data set for signal P10CALRT (the RES P C parameter value is 20 %

!BAR AMPL und SYNC = - 10 % !)

SIN2-TRANSITION	12.000 µs	200 ns	300 ns	866.5 mV	0.0 mV	0.0°
SIN2-TRANSITION	62.000 µs	200 ns	300 ns	0.0 mV	0.0 mV	0.0°

3. List of VITS Groups for automatic testline measurements

3.1 Testline group for automatic measurement of calibrated signals

LINE	SIGNAL
15	0CALRT
17	0CAL17
18	0CAL18
22	
330	0CAL30
331	0CAL31
335	

The Sync - amplitude is to set at 100 % (300 mV)

3.2 Testline group for automatic measurement of signals with - 5 % distortion (not RES P C)

LINE	SIGNAL
15	
17	N05CAL17
18	N05CAL18
22	
330	N05CAL30
331	N05CAL31
335	

The Sync - amplitude is to set at 95% (285 mV)

3.3 Testline group for automatic measurement of signals with - 10 % distortion (not RES P C)

LINE	SIGNAL
15	
17	N10CAL17
18	N10CAL18
22	
330	N10CAL30
331	N10CAL31
335	

The Sync - amplitude is to set at 90% (270 mV)

3.4 Testline group for automatic measurement of signals with +- 5 % distortion (not RES P C)

LINE	SIGNAL
15	
17	P05CAL17
18	P05CAL18
22	
330	P05CAL30
331	P05CAL31
335	

The Sync - amplitude is to set at 105% (315 mV)

**3.5 Testline group for automatic measurement of signals with + 10 % distortion
(not RES P C)**

LINE	SIGNAL
15	
17	P10CAL17
18	P10CAL18
22	
330	P10CAL30
331	P10CAL31
335	

The Sync - amplitude is to set at 110% (330 mV)

3.6 Testline group for automatic measurement of RES P C with - 5 % distortion

LINE	SIGNAL
15	N05CALRT
17	0CAL17
18	
22	
330	
331	
335	

The Sync - amplitude is to set at 100% (300 mV)

3.7 Testline group for automatic measurement of RES P C with - 10 % distortion

LINE	SIGNAL
15	N10CALRT
17	0CAL17
18	
22	
330	
331	
335	

The Sync - amplitude is to set at 100% (300 mV)

3.8 Testline group for automatic measurement of RES P C with + 5 % distortion

LINE	SIGNAL
15	P05CALRT
17	0CAL17
18	
22	
330	
331	
335	

The Sync - amplitude is to set at 100% (300 mV)

3.9 Testline group for automatic measurement of RES P C with + 10 % distortion

LINE	SIGNAL
15	P10CALRT
17	0CAL17
18	
22	
330	
331	
335	

The Sync - amplitude is to set at 90% (270 mV)

ANNEX 2 Extract of

Technische Pflichtenhefte der öffentlich-rechtlichen Rundfunkanstalten in der Bundesrepublik Deutschland	Pflichtenheft Nr. 8/1.1 Ausg. vom Okt 1974 1.1.4 Blatt 10
--	---

3. Level Generators

Level generators are used for generating accurately defined TV signal levels. Commercial level generators are for instance the Video Calibration Generator PM 5546 from Philips or the Video Standard Level Generator SNF from Rohde & Schwarz.

The accuracy of level generators can be easily tested by means of video level meters of sufficient accuracy, eg the Video Level Meter PM 5548 from Philips which has an accuracy of 0.1%.

A sample and hold circuit from Rohde & Schwarz (Fig. 10) has proved useful for measuring the level accuracy of line-frequency generators. With the aid of a switching field-effect transistor (T1), a capacitor (C1) is charged in each TV line for about 1 μ s. For this purpose a positive switching pulse (sampling pulse) with an amplitude of 10 V_{pp} and a width of 1 μ s from a pulse generator (eg Pulse Generator 101 from Data Pulse) is applied to point A in the circuit (Fig. 10). The frequency of the sampling pulse must be synchronized to the repetition frequency of the level generator and its phase

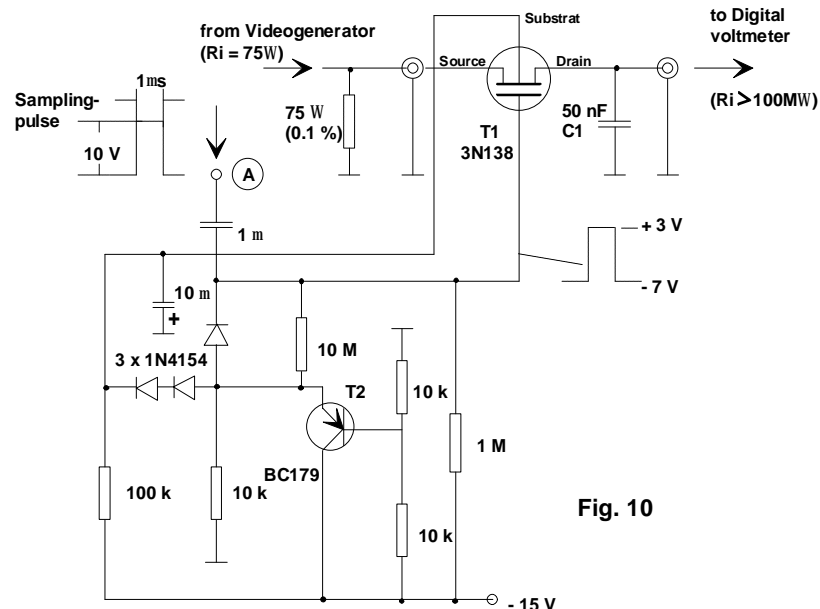

must be variable.

After several hundred sampling periods, a DC voltage corresponding to the signal level at the sampling point is present at the charging capacitor (C1) and can be accurately measured by means of a digital voltmeter (input impedance >100 MΩ). (See test setup Fig. 11). By shifting the phase of the sampling pulse which can be displayed in the oscillogram together with the test signal, the signal value at black and white and at the base line of the sync signal can be read from the digital voltmeter. The level difference corresponds to the test signal amplitude. The deviation of the signal level from the rated value in percent is specified as the level error.

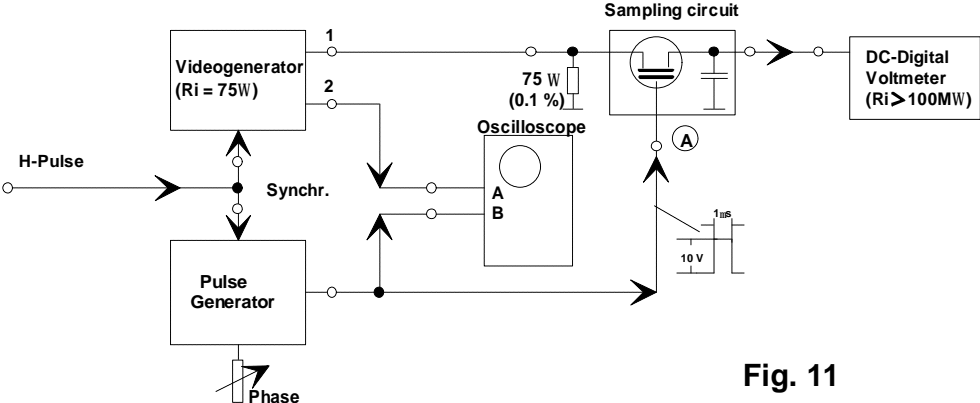

Fig. 11

It should be noted that even a slight low-frequency distortion (tilts) may impair the result of the level determination. To obtain accurate results in this case, the amplitude of the test signal is measured between defined points, as shown in Fig. 12 for the signal from the Video Standard Level Generator SNF (R&S).

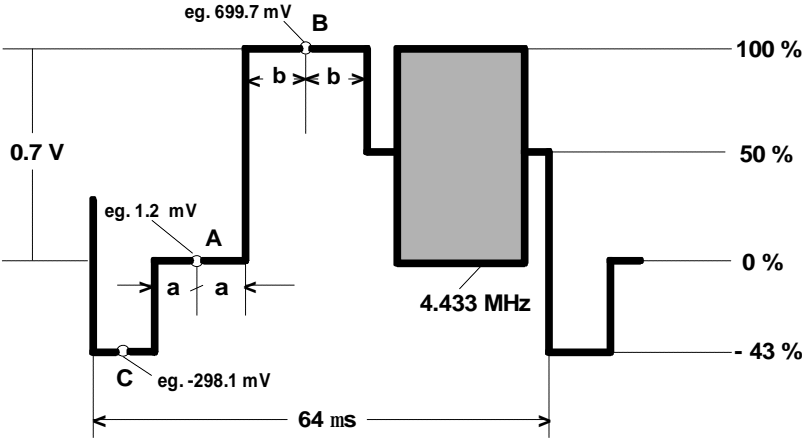

Fig. 12